

The innovative **GeoKey**[®] range offers slim stackable open-hole logging modules for the Oil and Gas industries.

Robertson Geo quality driven engineering is providing proven calibrated data from worldwide locations on an exceptional cost and results effective basis.



**ROBERTSON
GEO**

OIL & GAS

Unlocking Your GeoData

Oil & Gas GeoKey[®]

Publication No: 003 RGO/20

Open Hole Logging SLIMHOLE OR THRU-PIPE LOGGING SYSTEM

**Efficient, cost effective and proven
petrophysics solution**

**Compact, stackable logging modules and
surface equipment accessories**

**Highly engineered suite of technologies built
on over 40 years of expertise**

*Greater well depths and higher temperatures are bringing new demands on logging hardware.
GeoKey[®] provides a full range of measurements from a system as compact as possible in terms of length, weight and diameter.*

Oil & Gas

Robertson Geo is the market leader and globally the largest supplier of slimhole wireline logging instrumentation systems with its comprehensive offer of geophysical probes/modules and supporting surface equipment purpose designed and built in-house.

It is the only independent UK supplier of slimhole oilfield tools for open-hole logging.

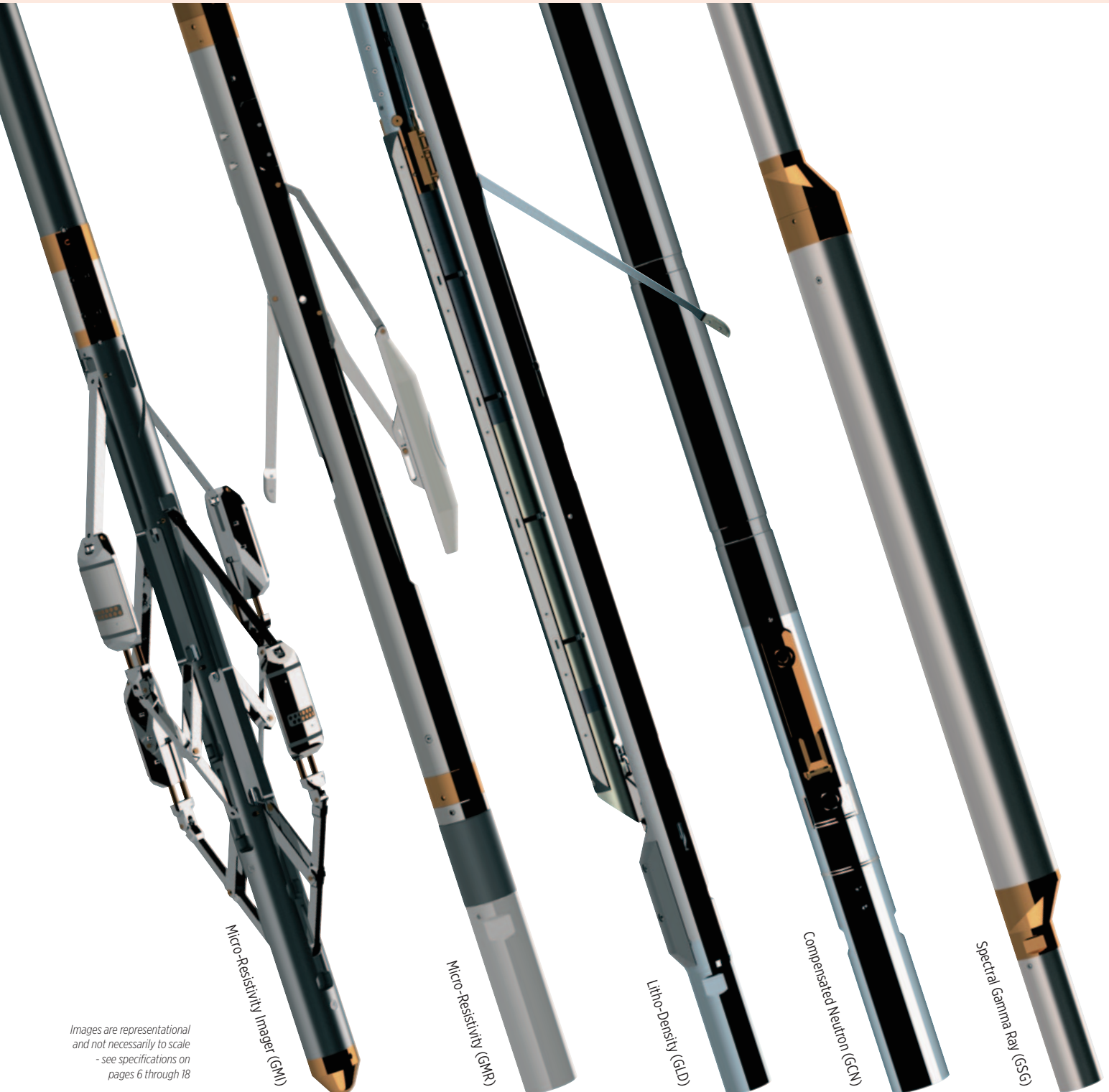

*Images are representational
and not necessarily to scale
- see specifications on
pages 6 through 18*

From a background of servicing the Oil and Gas exploration markets for over a decade, Robertson Geo has developed the GeoKey® range of compact, stackable, open-hole logging modules and surface equipment accessories.

Applications have included unconventional hydrocarbons, tar sands, oil shale, coal bed methane, deep geological surveys and water wells with systems being deployed to international locations on a global scale.



**ROBERTSON
GEO**

OIL & GAS

Unlocking Your GeoData

GeoKey®

Market trends are for wells constructed with small diameters in shale gas and unconventional resources and there is a focus towards reduced operating costs and site footprints for new onshore exploration and development wells.

Greater well depths and higher temperatures are bringing new demands on hardware requiring logging systems as compact as possible and providing a full range of measurements.

Robertson Geo is a specialist technology organisation dedicated to its supply and service logging technologies providing a results-based focus for the Oil and Gas industries that's not matched by large integrated multi-service providers.

The GeoKey® suite is designed and custom manufactured by Robertson Geo with a nominal module diameter of 2.5" (63mm). It's ideal for logging in small holes or wells with restricted access. The range operates at a maximum working temperature of 125°C and maximum pressure of 12,500psi.

GeoKey® can be deployed in vertical wells and wells approaching 80° inclination.

Logging services

Robertson Geo engineers are experienced, highly trained and fully certified for wireline logging operations and can be deployed to any global locations.

The complete GeoKey® suite of equipment is available on a service basis operated by these field crews. They are capable of executing prolonged logging operations with minimum outside support, including handling of nuclear based tools and data processing.

These are very cost effective contracting services in circumstances where projects do not justify purchasing equipment and the necessary back up facilities.

Equipment supply

All Robertson Geo modules are fully tested and calibrated at the Deganwy facility prior to dispatch, eliminating testing time on site and ensuring the modules are fully operational prior to downhole use.

Depending on customer needs operational and customised training can be provided; this for winch use, module deployment, logging techniques, data capture and equipment maintenance and troubleshooting.

Equipment lease to purchase

Robertson Geo logging equipment is available to rent, either as a full system or as individual modules. Customised borehole and classroom training can be provided. Equipment packages can be offered on a lease to purchase basis for customers who prefer to buy systems for longer term projects.

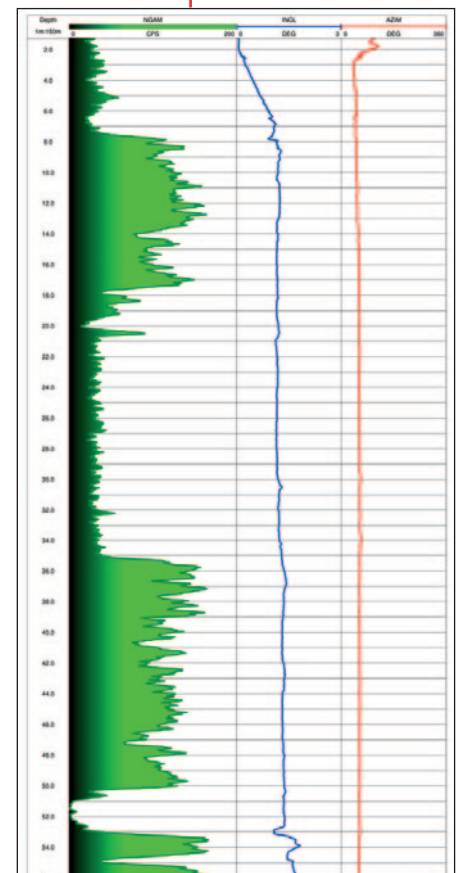

Example of data created by the Telemetry module (GTM).

Further data examples are shown with each specification page for modules and where applicable surface equipment on pages 6 through 18.

Robertson Geo is the only logging services provider with a QMS certified to ISO 9001, calibrating all of its logging systems and uniquely using an on-site borehole for testing at its Deganwy calibration and test well facility that includes calibration blocks and autoclaves capable of testing complete modules at temperatures up to 175°C and pressures up to 138MPa simultaneously.

GeoKey® modules

Optimised for responses in boreholes up to 12" with nuclear designs supported by Monte Carlo modelling and resistivity tools by finite element analysis.

Modules have been benchmarked against industry standard formations such as the Callisto Test Facility UK.

The use of low level radioactive sources without compromising data quality makes GeoKey® unique and highly cost effective. By Q1 2019, the full suite of GeoKey® modules will be verified at a state-of-the-art calibration and test facility in Europe under strict metrology tolerances.

Telemetry (GTM): the topmost acquisition tool in the stack, immediately below the Downhole Tension/Compression module. *See page 6*

Downhole Tension (GDT): positioned above the Telemetry section in order that it can measure the maximum possible tool weight. *See page 7*

Litho-Density (GLD): combines a borehole-corrected bulk density measurement with a photoelectric lithology log (Pe). *See page 8*

Compensated Neutron (GCN): provides an environmentally compensated porosity log in mud filled holes. *See page 9*

Dual Laterolog (GDL): provides deep and medium penetrating resistivity measurements using a classic Laterolog-9 electrode configuration, it is the preferred alternative to the array induction probe in saline muds. *See page 10*

Dual Induction (GDI): provides conductivity logs with deep and medium depths of investigation to profile borehole fluid invasion into the formation. *See page 11*

Micro-Resistivity (GMR): provides a high-vertical-resolution micro-focused resistivity measurement within the flushed zone. *See page 12*

Micro-Resistivity Imager (GMI): provides a high-resolution spatially orientated image of features on the borehole walls. *See page 13*

Compensated Sonic/CBL (GSC): provides multi-spacing digital acoustic-velocity (formation-slowness) measurements with high vertical resolution. *See page 14*

Spectral Gamma Ray (GSG): analyses the energy spectrum of gamma radiation from naturally occurring or man-made radioactive isotopes. *See page 15*

4-Arm Caliper (GXY): two pairs of linked caliper arms giving borehole size and orientated shape, the combination of X-Y caliper data allows for accurate borehole volume calculations, break-out investigations and stress analysis. *See page 16*

Ultrasonic Noise Detector (GND): detects points of entry of high-pressure gas into an open borehole by listening for an ultrasonic signature. *See page 17*

Surface equipment

GeoKey® modules are compatible with third party, hydraulic and standard winches for use up to 4,500m using 5/16" hepta-cable.

GeoKey® runs through Robertson Geo's own unique cable head system and is supported by a full range of accessories including, downhole tension, centralisers/decentralisers, offset joints, base and field calibrators and radioactive sources, available through proven and industry standard third party partners.

The surface interface uses the industry standard log acquisition software Warrior™, by Scientific Data Systems Inc.

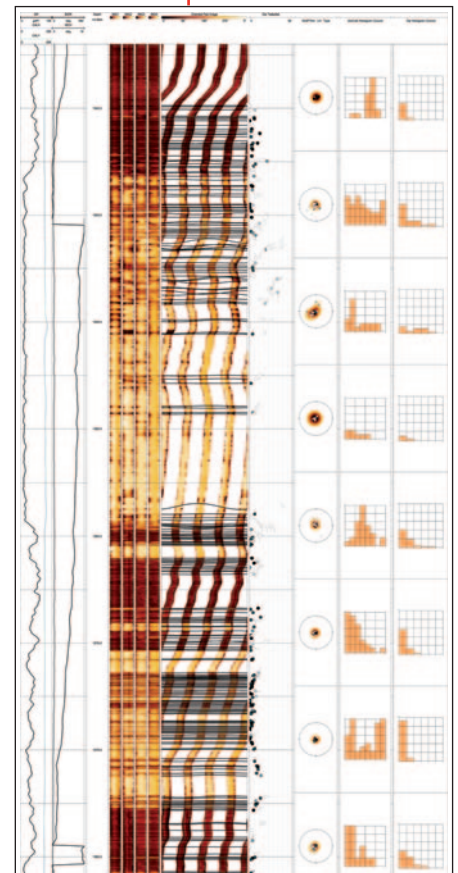

Example of data created by the Micro-Resistivity Imager module (GMI).

Further data examples are shown with each specification page for modules and where applicable surface equipment on pages 6 through 18.



Oil & Gas Applications

Representative examples to show **Essential**, **Intermediate** and **Advanced** systems as a benchmark for identifying the level of data and interpretation required for individual locations and characteristics.

Robertson Geo support teams are always available for further information and discussion when considering system applications at support@robertson-geo.com

Essential

GeoKey® Surface Acquisition System
 Telemetry (GTM)
 Litho-Density (GLD)
 Compensated Neutron (GCN)
 Dual Laterolog (GDL)
 or Dual Induction (GDI)

Intermediate

GeoKey® Surface Acquisition System
 Telemetry (GTM)
 Litho-Density (GLD)
 Compensated Neutron (GCN)
 Dual Laterolog (GDL)
 or Dual Induction (GDI)
 Micro-Resistivity (GMR)
 Compensated Sonic (GSC)

Advanced

GeoKey® Surface Acquisition System
 Telemetry (GTM)
 Litho-Density (GLD)
 Compensated Neutron (GCN)
 Dual Laterolog (GDL)
 or Dual Induction (GDI)
 Micro-Resistivity (GMR)
 Micro-Resistivity Imager (GMI)
 Compensated Sonic (GSC)
 Spectral Gamma Ray (GSG)

See module and surface equipment specifications pages 6 through 18.

Telemetry (GTM)

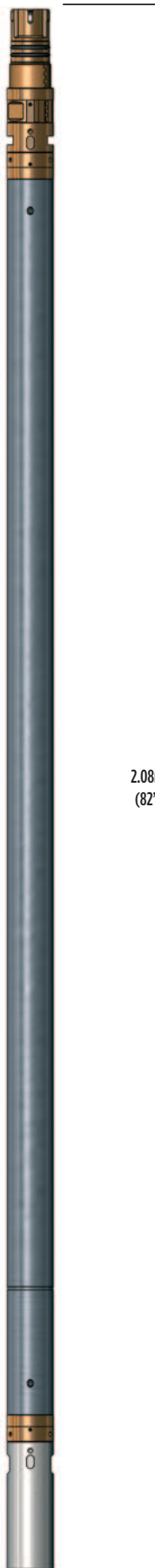

Accelerometers & Magnetometers

2.08m
(82")

Gamma

Telemetry Module

The GeoKey® Telemetry module with Navigation pack is the topmost acquisition tool in the stack, immediately below the Downhole Tension/Compression module.

Its main function is to collect and combine digital data from all other tools and to transmit this in a digital form via the logging wireline to the surface acquisition system. It also provides control functions and tool power to the other logging tools.

Principle of Measurement:

All tools in the stack communicate with the Telemetry module over a common internal RS485 data bus. The Telemetry module organises this data and transmits it to the surface using proprietary high-speed protocol. Data is acquired on a depth basis with a sample interval selected to optimise measurement resolution/logging speed.

SPECIFICATION:

Features

- Bi-directional digital transmission
- Compatible with industry standard 5/16" or larger diameter cable
- Continuous borehole orientation log

Measurements

- Natural Gamma
- Vector data sourced from orientation package creates:
 - Borehole inclination
 - Borehole direction
 - Borehole drift
 - True vertical depth
 - Relative Bearing
 - Magnetic Tool Face
 - Total G field
 - Total B field

Applications

- Natural gamma:**
 - Lithology indication
 - Shale measurement
 - Bed-boundary/bed thickness measurement
 - Correlation between logs and wells
- Borehole inclination and direction:**
 - QA of borehole construction
 - Bed-thickness correction
 - Bed-thickness estimation
 - Surveying and deviation checks

Operating Conditions

Borehole type: open hole Ø:102mm (4") to 305mm (12")

Specifications

Diameter:	63mm (2.5")
Length:	2.08m (82")
Weight:	23kg (51lb)
Max. temperature:	125°C
Max. pressure:	86MPa (12,500psi)
Inclinometer:	Triaxial Accelerometers
Azimuth:	Triaxial Magnetometers
Natural gamma detector:	101 mm x 38 mm NaI(Tl) Scintillation crystal

Part Numbers

1017919 Telemetry - includes gamma, Navigation pack

Accessories:

- 1015464 Natural gamma check calibration blanket
- 1004127 Make-up plate
- 1004128 Assembly wrench

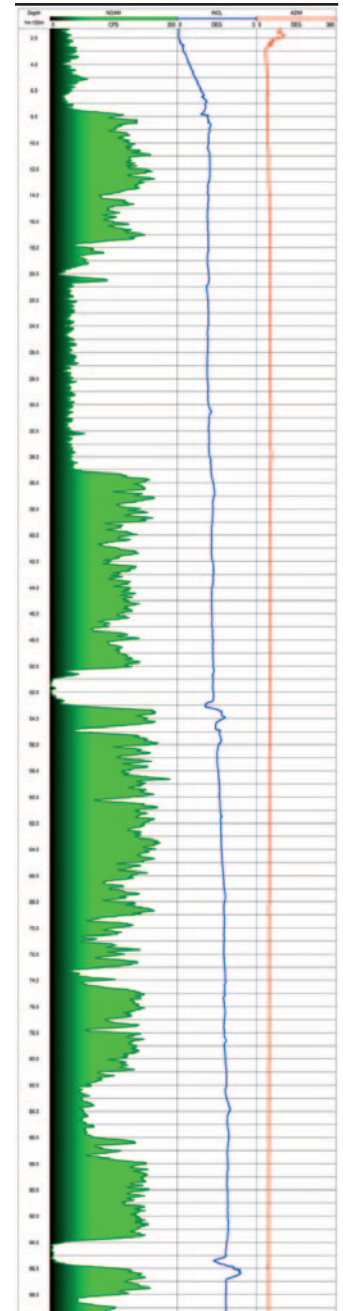

Example of logging data

Downhole Tension (GDT)



1.11m
(43.7")

Downhole Tension Module

The Downhole Tension module is positioned above the Telemetry section in order that it can measure the maximum possible tool weight.

Only the Isolator and Cablehead sections can be used above the Tension/Compression module.

Principle of Measurement:

This section is useful for cable jams when the downhole tension can be compared to the surface wireline tension readout. In the event of fishing for a tool, the compression can give vital indication that the tool is latched correctly.

SPECIFICATION:

Features

- Tension compression output
- Fits directly beneath cablehead
- Compatible with industry standard 5/16" or larger diameter cable
- Downhole tension can be compared to the surface wireline tension readout to help avoid cable jams and assist in finishing operations

Measurements

- Downhole Compression
- Downhole Tension

Applications

- Detection of cable jams by comparison with surface wireline tension readout
- During fishing operations, compression provides confirmation of correct tool latching

Calibration

- Both tension and compression readings are configured to give kgF units

Operating Conditions

- Borehole type: all

Specifications

- Diameter: 63 mm (2.5")
- Length: 1.11 m (43.7")
- Weight: 16 kg (36lb)
- Max. operating temperature: 125°C
- Max. operating pressure: 86MPa (12,500psi)
- Max. Tension/Compression: 1815kgF (4000lbF)

Part Numbers

- 1016423 Downhole Tension/Compression module

Litho-Density (GLD)

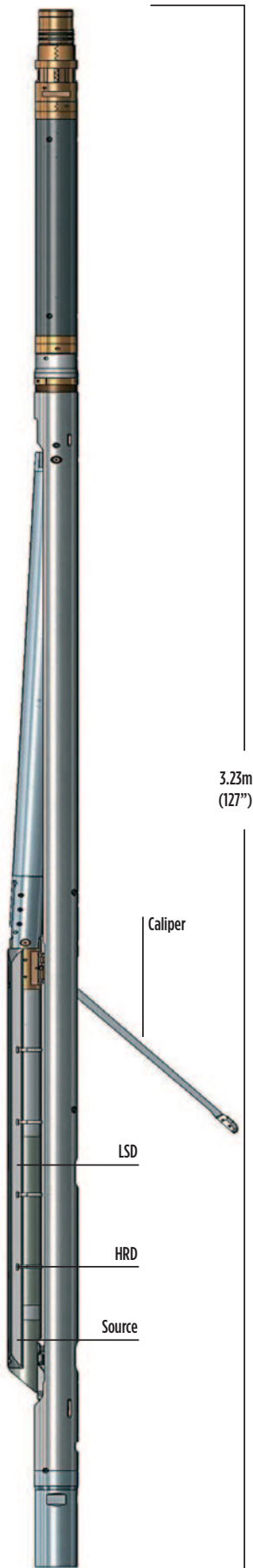

Litho-Density Module

The Litho-Density module combines a borehole-corrected bulk density measurement with a photoelectric lithology log (Pe).

The radioactive source and detectors are mounted in an articulated skid that is maintained in contact with the borehole wall by a powered backup arm to minimise borehole rugosity effects. The arm also doubles as a caliper measurement. The tool may be combined with compensated neutron and focused induction measurements in the classic 'triple-combo' configuration.

Principle of Measurement:

Gamma radiation from a ^{137}Cs source in the tool is Compton scattered by the formation and detected by two scintillation detectors. The relative intensities of the radiation at each detector give a measurement of formation bulk density. The photoelectric measurement is derived from the ratio of the gamma intensities in high and low energy windows at a detector. It depends of the formation atomic number and is a good lithology indicator. The measurements are influenced by the borehole environment. These effects are minimised by corrections calculated by extensive Monte Carlo modelling and benchmarked to standards at the Callisto facility in Leicestershire, UK.

SPECIFICATION:

Features

- Drift eliminated by digital circuitry and active calibration loops based on internal reference sources
- Well characterised tool response based on computer calculations
- Tungsten carbide coated wear plate on skid can be replaced in the field
- High-resolution measurement
- Maximum data sampling rate is 1cm (0.4")

Measurements

- Bulk density (ρ_B)
- Correction indicator ($\Delta\rho$)
- Photoelectric effect (pef)
- Borehole Diameter

Applications

- Matrix Identification
- Formation fluid analysis
- Porosity from density

Operating Conditions

- Borehole type: open hole 4" to 12"

Specifications

- (HRD; LSD) density sensors offsets 160 mm (6.3"), 399 mm (15.7")
- Diameter: 84mm (with stand-off), 74mm (without stand-off)
- Length: 3.23m (127")
- Weight: 57kg (125.6lb)
- Max. temperature: 125°C
- Max. pressure: 86MPa (12,500psi)
- Density range: 1.1 -2.95 g/cc +/- 0.005 g/cc (1 std deviation)
- Density radius of investigation: 102 mm (4") to 152 mm (6")
- Photoelectric range: 1-10 Barns
- Caliper range: 90mm (3.54") - 300mm (12")
- Caliper resolution: 1 mm (0.04")

Part Numbers

- 1003937 Litho-Density module

Accessories:

- 1013961 18.5GBq ^{137}Cs source
- 1004126 Source holder
- 1004125 Source transport pig
- 1004123 Source handling tool set
- 1004129 Density/ Pe calibrator
- 1004131 Caliper calibrator

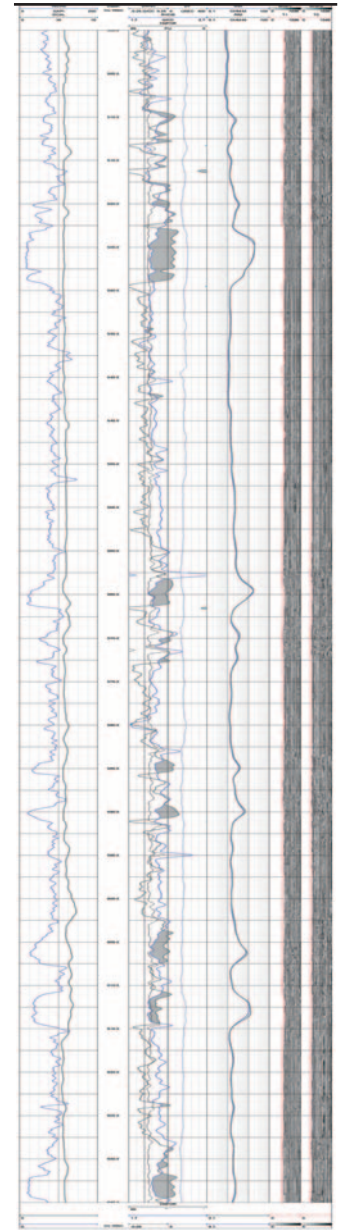

Example of logging data

Compensated Neutron (GCN)

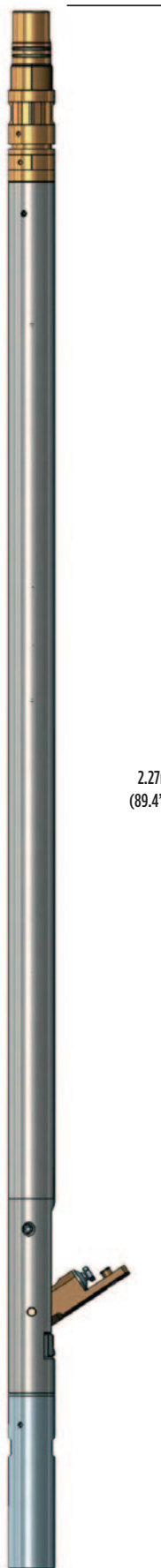

Compensated Neutron Module

The Compensated Neutron module provides an environmentally compensated porosity log in mud-filled open holes.

An alternative epithermal detector configuration is available for air/gas filled holes. The tool design has been optimised to provide good performance at acceptable logging speeds while still using a relatively small 92GBq 241Am-Be source. It is combinable with the Litho-Density and Dual Induction log in a single run.

Principle of Measurement:

The Compensated Neutron measurement uses two ^3He proportional detectors and a side-door entry sealed neutron source. Fast neutrons emitted by the source are scattered and slowed down by light elements (principally hydrogen) in the formation. The ratio of the neutron flux reaching the detectors depends on the formation hydrogen index/formation porosity.

Neutron porosity measurements are affected by the borehole environment. These effects are compensated in software by algorithms calculated by Monte Carlo modelling and benchmarked to standards at the Callisto facility in Leicestershire, UK.

SPECIFICATION:

Features

- Well characterised tool response based on computer calculations for limestone, sandstone and dolomite
- Fully digital telemetry combines with density, induction and other logging probes
- Low-activity source requirements for safe handling and cost reduction
- High-resolution measurement
- Maximum data sampling rate is 1cm (0.4")

Measurements

- Porosity ϕ
- Ratio long/short and raw counts

Applications

- Porosity
- Lithology (in conjunction with other logs)
- Gas/light hydrocarbon detection
- Correlation between wells

Operating Conditions

- Borehole type: fluid filled \varnothing :102mm (4") to 305mm (12")

Specifications

- Diameter: 63mm (2.5")
- Length: 2.27m (89.4")
- Weight: 28kg (62lb)
- Max. temperature: 125°C
- Max. pressure: 86MPa (12,500psi)
- ^3He detectors offsets: 203 mm (8") and 406 mm (16")
- Porosity Range: -15% to 60% (limestone scale)
- Resolution: 0.6 PU in 152 mm (6") borehole at 15% porosity
- Radius of investigation: 152 mm (6") - 406 mm (16")

Part Numbers

- 1003942 Compensated Neutron module

Accessories:

- 1013962 92 GBq 241Am-Be source
- 1004124 Source holder
- 1004122 Source transport pig
- 1004123 Source handling tool set
- 1004137 Field check jig
- 1017411 Dual-band eccentriciser for neutron/telemetry

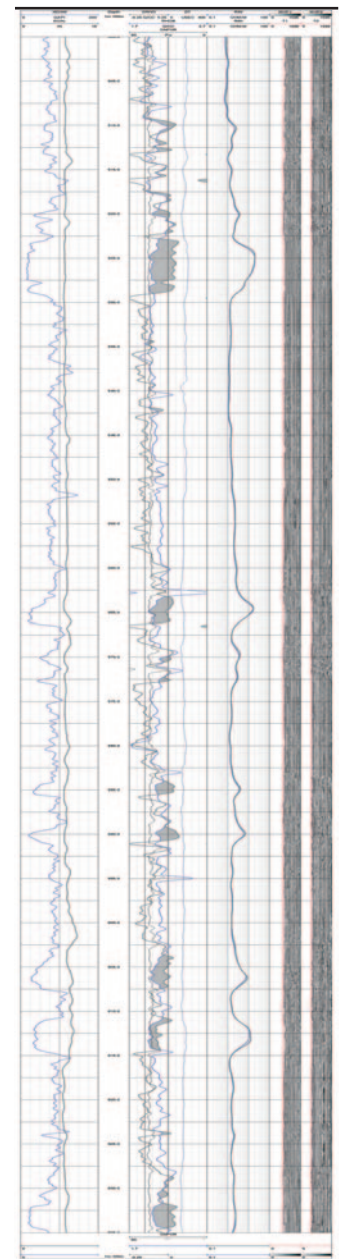

Example of logging data

Dual Laterolog (GDL)

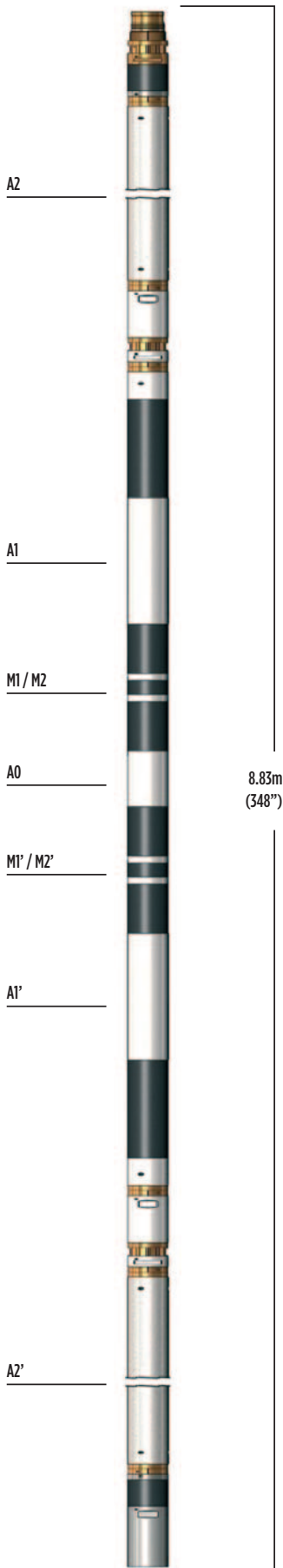

Dual Laterolog Module

The Dual Laterolog module provides deep and medium penetrating resistivity measurements using a classic laterolog-9 electrode configuration. It is the preferred alternative to the array induction probe in saline drilling muds.

The module is run below a solid insulated bridle that includes the SP, voltage-reference and Groningen measurement electrode. A specific isolator module is used with this module. This insulated section is positioned between the cable head and the DHT module (if used).

Principle of Measurement:

An alternating current from the central A0 electrode passes through the formation and returns to a surface fish (deep resistivity) or to electrodes A2 and A2' on the module (shallow resistivity). A bucking current flowing from the guard-electrode pair A1 and A1' is controlled to maintain the monitor electrode pairs M1M2 and M1'M2' at the same potential. These equipotential surfaces constrain the measure current path to a disc of thickness 2ft.

SPECIFICATION:

Features

- Down-hole digital control of current sequence for deep and shallow measurements
- Focused measurement gives high vertical resolution
- Constant power drive for wide dynamic range
- Voltage reference and SP measurement from electrode on rigid bridle
- Stackable with GeoKey® slim oilfield system

Measurements

- Deep focused resistivity (LLD)
- Shallow focused resistivity (LLS)
- SP
- Groningen effect

Applications

- Invasion profile
- Fluid Saturation
- Permeability indication

Operating Conditions

Borehole type: open-hole, mud-filled 4" - 12"

Specifications

Diameter:	63mm (2.5")
Total length:	8.83m (348") combined
Max section length:	3.37m (133")
Weight:	113.5kg (250lb) (3 sections)
Max. operating temperature:	125°C
Max. operating pressure:	86MPa (12,500psi)
Range:	0.1 to 40,000 ohm-m
Accuracy:	5% at 1000 ohm-m
Resolution:	1% measured value

Part Numbers

10013886 Dual Laterolog module

Accessories:

- 10015009 Solid bridle with reference electrode
- 10013888 Field test box with leads and clamps

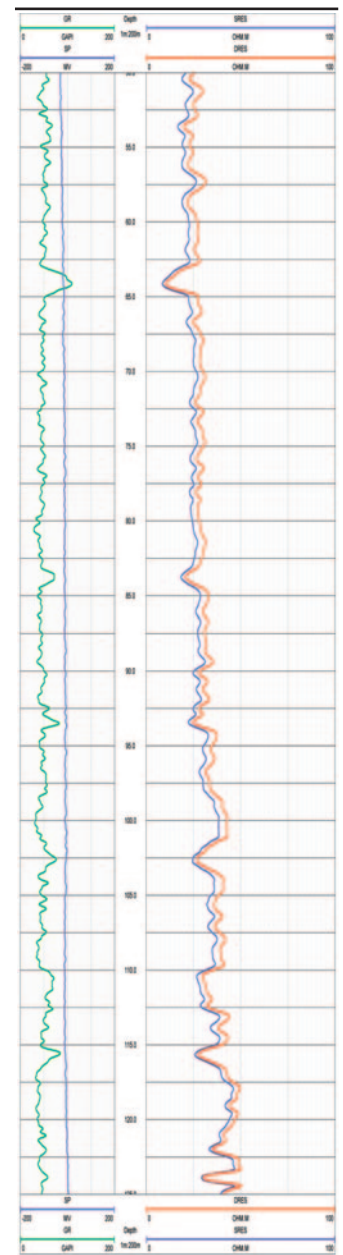

Example of logging data

Dual Induction (GDI)

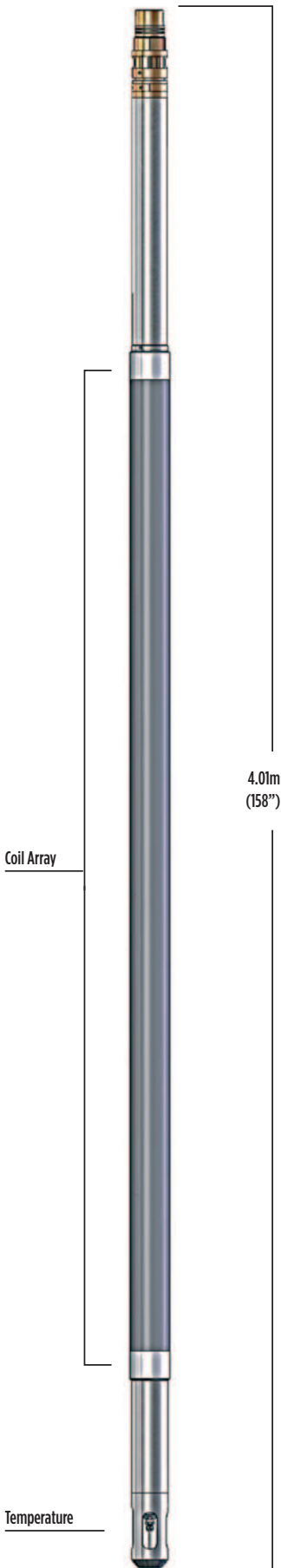

Dual Induction Module

The Dual Induction module provides conductivity logs with deep and medium depths of investigation to profile borehole fluid invasion into the formation.

The tool uses an 'array' technique where multiple sets of in-phase and out-of-phase receiver responses are processed and summed to emulate the vertical and radial responses of classic 6FF40 ILD and ILM logs. The tool may be combined with other measurements and is run at the base of the stack. The module includes a fast-response platinum resistance thermometer for measurement of external borehole temperature.

Principle of Measurement:

An oscillating high-frequency magnetic field created by a transmitter coil within the module induces an alternating electrical current within the surrounding conductive formation. This current, in turn, induces voltages within multiple receiver coils in the module proportional to formation conductivity. The transmitter-receiver spacing determines the depth of investigation of the measurements.

SPECIFICATION:

Features

- Multiple coil 'array' measurement using computer processing to synthesise tool responses
- Internal temperature compensation for low drift
- Oil-filled and pressure-balanced mandrel
- Fully digital telemetry combines with density, neutron and other logging probes
- High-resolution measurement
- Maximum data sampling rate is 1cm (0.4")
- Includes external temperature measurement

Measurements

- Deep conductivity (ILD)
- Medium conductivity (ILM)
- Temperature and differential temperature

Applications

- Hydrocarbon saturation
- Porosity
- Lithology (in conjunction with other logs)
- Correlation between wells

Operating Conditions

Borehole type: open hole \varnothing :102mm (4") to 305mm (12")

Specifications

Diameter:	70mm (2.7")
Length:	4.01m (158")
Weight:	31kg (68lb)
Max. temperature:	125°C
Max. pressure:	86MPa (12,500psi)
Operating Frequency:	25.6 kHz
Number of coils:	1 x Tx; 4 x Rx; 4 x focusing
Numbers of spires for each solenoid:	4 x 3-coil sub-arrays
Effective Tx-Rx Spacing:	457mm (18"), 686mm (27"), 914mm (36"), 1.50 m (60") (nominal spacing)
Drift over T° range:	<2 mS/m
Resistivity range:	0 to 200ohm-m (Qualitative indication up to 2000ohm-m)
Depth of investigation:	ILD 150cm (60") ILM 75cm (30")

Part Numbers

1003947 Dual Induction module with temperature

Accessories:

- 1004133 Calibration loop
- 1004134 Fin stand-off (set of two)

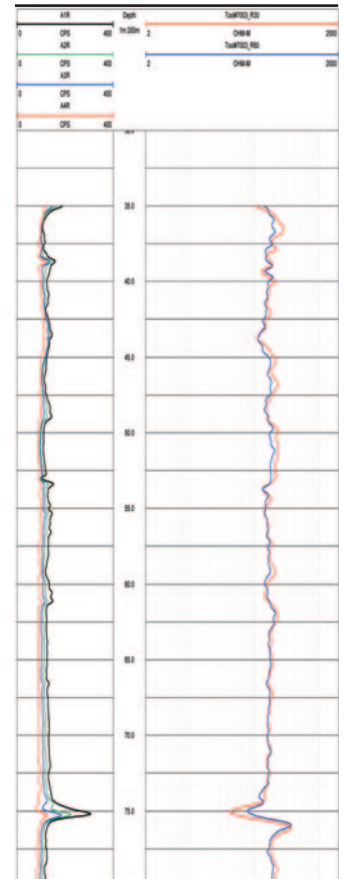

Example of logging data

Micro-Resistivity (GMR)



Micro-Resistivity Module

The Micro-Resistivity module provides a high-vertical-resolution micro-focused resistivity measurement within the flushed zone.

The measurement electrodes are mounted on a flexible pad which is maintained in contact with the borehole wall by a motor-driven back-up/caliper arm. The measurement pad is interchangeable to give either micro-focused resistivity or micro-normal/micro-lateral electrode geometries. The tool is stackable with all other slim-2.5" oilfield probes. When combined with the Dual Laterolog it replaces the lower guard electrode.

Micro-focused resistivity principle of measurement:

A central current-injection electrode is surrounded by 3 concentric ring electrodes in a circular LL-7 configuration. The measure current is focused into a narrow beam which penetrates the mud-cake to give a resistivity measurement in the flushed zone (Rxo) beyond.

Micro-normal/micro-lateral principle of measurement:

Three in-line button electrodes, 1" apart, are configured to provide simultaneous 2" micro-normal and 1.5" micro-lateral measurements. Separation of the two measurement values due to their different depths of investigation gives an indication of mud-cake thickness.

SPECIFICATION:

Features

- High-vertical-resolution resistivity
- Robust back-up arm ensures good pad contact
- Pad interchangeable in field
- Fully stackable with other Robertson Geo oilfield probes

Measurements

- Resistivity of invaded zone (Rxo)
- Borehole diameter

Applications

- Determination of moveable hydrocarbons
- Correction of Rt for invasion
- Indication of permeability
- Precise location of bed boundaries

Operating Conditions

- Borehole type: open-hole, mud/water filled
- Ø: 102mm (4") to 305mm (12")

Specifications

- Diameter: 102mm (4") (with 8" pad)
- Length: 3.63m (142.9")
- Weight: 55kg (121lb)
- Max. temperature: 125°C
- Max. pressure: 86MPa (12,500psi)
- Range: 0.2 to 2,000ohm.m
- Caliper range: 120mm (4.75") – 400mm (12")

Part Numbers

- I015642 Micro-Resistivity module

Accessories:

- I015644 Spare micro-focused resistivity pad
- I015646 Spare micro-normal/micro-lateral pad

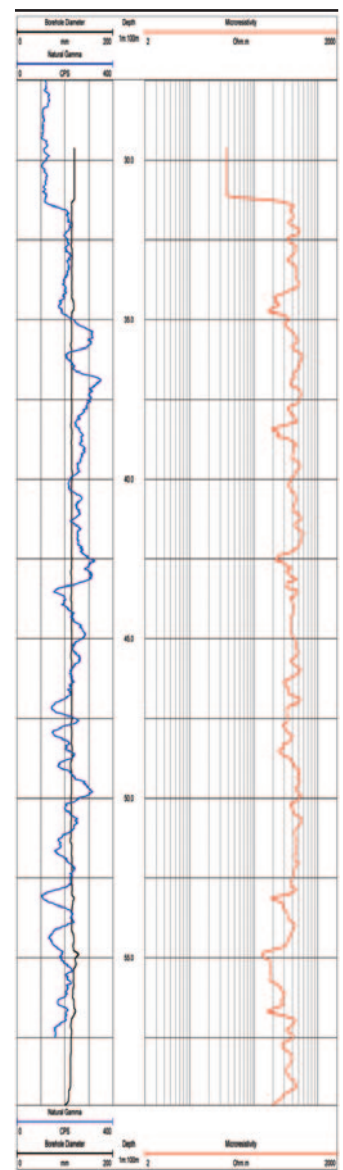

Example of logging data

Micro-Resistivity Imager (GMI)



3.36m
(132")

Imaging
Pads

Micro-Resistivity Imager Module

The Micro-Resistivity Imager module provides a high-resolution spatially oriented image of features on the borehole walls.

The tool includes 4 pads each containing twelve button electrodes mounted on 2 pairs of powered arms. The current emitted by each electrode is focused into a narrow beam and returns to a remote part of the tool body. The current from each electrode is measured and digitised in each pad and transmitted to the surface by a separate telemetry module using a proprietary high-speed communications system. The tool may be run on 7-core cables and is compatible with the standard Robertson Geo oilfield surface system running Warrior™ software.

SPECIFICATION:

Features

- 48 button electrodes (12 on each pad)
- Data sampling interval 60ms with real-time transmission of all data
- Exchangeable pads for hole sizes between 110mm and 220mm
- 40% wall coverage in 146mm borehole

Measurements

- Micro-resistivity
- Borehole diameter (XY caliper)

Applications

- Identification of faults and folding
- Location/characterisation of fractures
- Determination of structural dips
- Analysis of sedimentary structures and cross-bedding
- Core orientation

Operating Conditions

- Borehole type: open-hole, mud/water filled
Ø:102mm (4") to 257mm (10.1")
- Centralisation required

Specifications

- Diameter: 94mm (3.7") (with 8.5" pad)
- Length: 3.36m (132")
- Weight: 47kg (103.5lb)
- Max. temperature: 125°C
- Max. pressure: 86MPa (12,500psi)
- Caliper accuracy: +/- 5mm
- Inclination accuracy: +/- 0,1 deg
- Azimuth accuracy: +/- 5 deg
- Button current precision: 16-bit (48 button electrodes - 12 on each pad)
- Resolution (radial & vertical): 7mm (46% wall coverage in 146mm borehole)
- Logging speed: 300m/hr
- Borehole range: 114mm (4.5") to 250mm (10")

Part Numbers

- 1015579 Micro-Resistivity Imager module

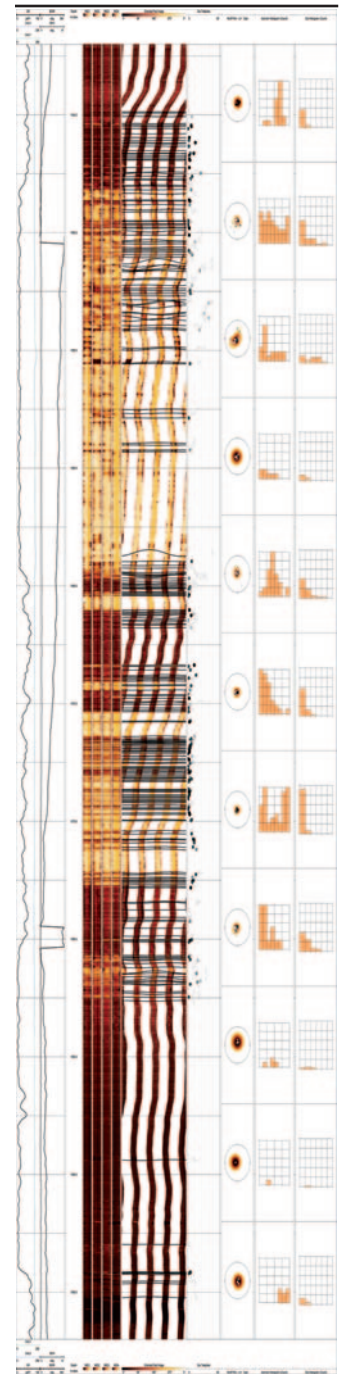

Example of logging data

Compensated Sonic/CBL (GSC)

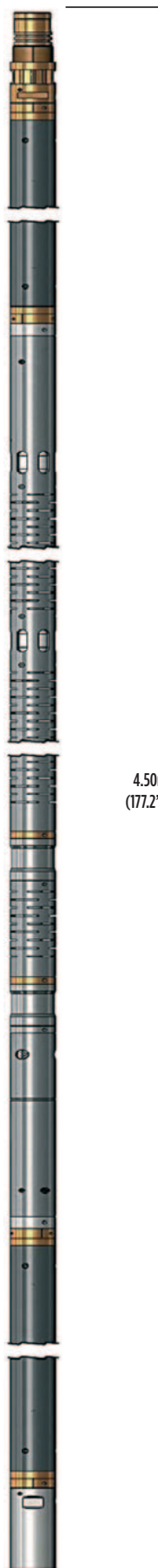

4.50m
(177.2")

Compensated Sonic/CBL Module

The Compensated Sonic/CBL module provides multi-spacing digital acoustic-velocity (formation-slowness) measurements with high vertical resolution.

Full-waveform recording and CBL measurements are also available. The tool can be stacked with other tools.

Principle of Measurement:

Two piezoelectric transmitters stimulated by high-voltage pulses radiate high-frequency acoustic waves through the borehole fluid and formation to the receiver pair. An accurate quartz clock measures the arrival time of the first compressional wave at each receiver from each transmitter firing. The data is automatically processed to remove the influence of the borehole fluid path, tool tilt and caving (depth-derived borehole compensation). The attenuation of the first arrival is related to the bond quality and the strength of the cement, giving a Cement Bond Log (CBL).

SPECIFICATION:

Features

- High-energy transmitters for maximum penetration
- Two monopole receivers and two monopole transmitters
- Depth-derived borehole compensation for borehole tilt and caving
- Amplitude and waveform data in CBL mode with industry standard 3' and 5' spacings
- Oil-filled mandrel with pressure compensation

Measurements

- Formation velocity (slowness)
- Tx-Rx spacings: 3ft, 4ft, 5ft, 6ft
- Compensated DT from each receiver pair
- Cement Bond Log (CBL) amplitude and waveform

Applications

Open Hole:

- Lithology
- Porosity
- Rock strength and elasticity
- Fracture indication
- Time to depth correlation for seismic

Cased Hole:

- Location of poor or missing cement behind casing

Operating Conditions

- Borehole type: water/mud filled; open/cased
- Ø: 102mm (4") to 305mm (12")

Specifications

- Diameter: 63mm (2.5")
- Length: 4.50m (177.2")
- Weight: 50kg (110lb)
- Max. temperature: 125°C
- Max. pressure: 86MPa (12,500psi)
- Number of piezoelectric transmitters and offsets: 2 (4.75ft, 5.75ft)
- Frequency of emission: 20 kHz
- Number of receivers and offsets: 2 (8.75ft, 10.75ft)
- Range: 40 - 240 µs/ft (130-787 µs/m)
- Resolution: 0.25 µs/ft
- Vertical Resolution: 1ft or 2ft

Part Numbers

- 1013889 Compensated Sonic/CBL module

Accessories:

- 1014803 6-arm centraliser (2 required)

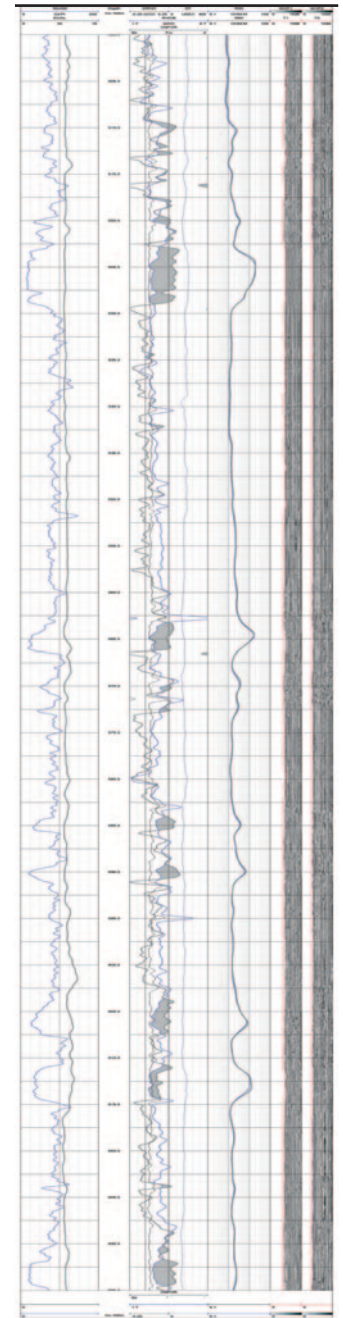

Example of logging data

Spectral Gamma Ray (GSG)

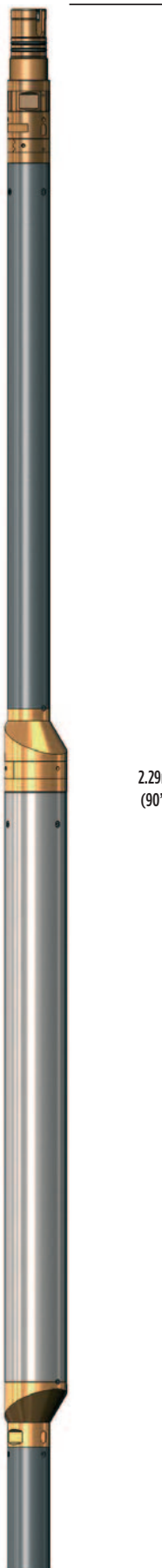

2.29m
(90")

Detector

Spectral Gamma Ray Module

The Spectral Gamma Ray module analyses the energy spectrum of gamma radiation from naturally occurring or man-made radioactive isotopes.

The module includes a large volume detector contained in a Dewar flask for thermal stability. The Full Spectrum Analysis (FSA) technique used to compute the contributions of individual isotopes makes optimum use of all acquired data. It is also used for gain stabilisation by mapping spectral shifts between successive depth intervals. Borehole size, mud weight and probe position effects are compensated by the software.

Principle of Measurement:

Gamma photons produced by radioactive decay of unstable isotopes create light emissions in the gamma scintillation detector. The amplitude of the pulse depends of the photon energy. An analyser within the module separates the pulses into separate channels according to their amplitudes. Count-rates from groups of channels are converted in real-time by the surface software to concentrations of originating elements using preset algorithms.

SPECIFICATION:

Features

- Large-volume scintillation detector for high sensitivity
- Dewar flask for thermal stability
- Full spectrum dynamic drift compensation

Measurements

- Uranium (ppm)
- Thorium (ppm)
- Potassium (%)
- Gross gamma
- Full spectrum (static measurement)

Applications

- Lithology determination
- Mineral detection
- Sedimentology
- Improved shale-content computation
- Correlation
- Contamination studies

Operating Conditions

- Borehole type: open/cased, water/air-filled

Specifications

- Diameter: 63mm (2.5") - max dia. 89mm (3.5")
- Weight: 40.5kg (89.3lb)
- Length: 2.29m (90")
- Max. Temperature: 125°C
- Max. pressure: 86MPa (12,500psi)
- Detector: Na(Tl) scintillator
- Detector Size: 51mm x 300mm
- Energy range: 100keV to 3MeV
- Number of channels: 300

Part Numbers

- 1016424 Spectral Gamma Ray module
- 1015464 Natural-Gamma Calibration Blanket

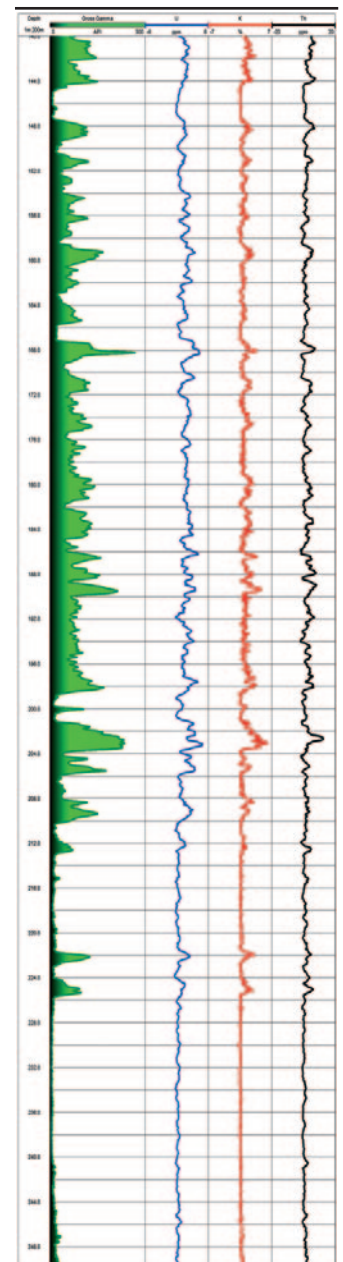

Example of logging data

4-Arm Caliper (GXY)

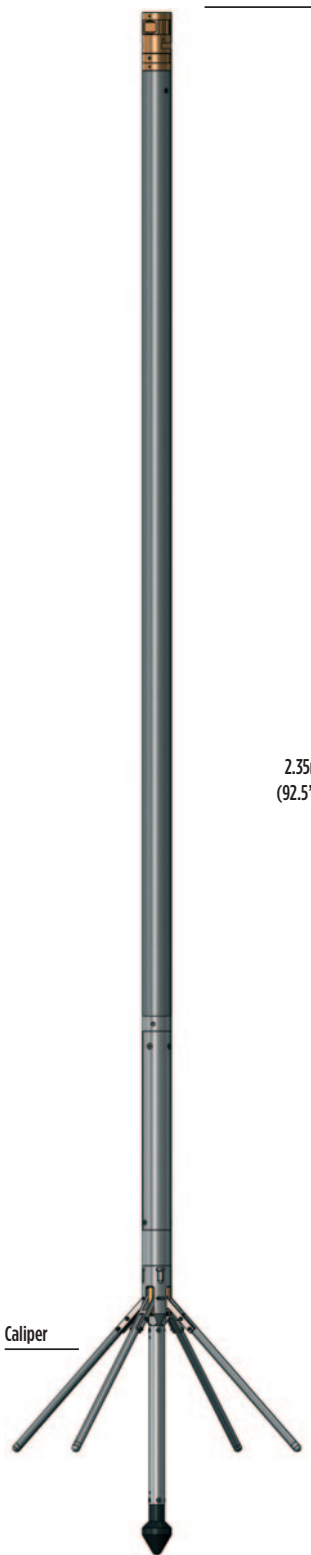

4-Arm Caliper Module

The 4-Arm Caliper module consists of two pairs of linked caliper arms providing borehole size and orientated shape.

The combination of X-Y caliper data allows for accurate borehole volume calculations, break-out investigation and stress analysis.

Principle of Measurement:

The X-Y caliper provides continuous measurements of the borehole diameter from two independent pairs of linked arms. Data from these can be combined with orientation data from the Telemetry module to provide an accurate record of borehole orientation, size and shape.

SPECIFICATION:

Features

Sensitive X-Y caliper

Measurements

X and Y calipers
Borehole volume (derived)

Applications

Hydrocarbons/water/minerals/engineering
Borehole diameter in two axes
Borehole break-out for stress analysis
Cracks, fissures and casing defects

Operating Conditions

Borehole type: open/cased, water/air-filled
Centralisation: recommended

Specifications

Diameter: 63mm
Length: 2.35m (92.5")
Weight: 23kg
Temperature: 125°C
Max. pressure: 5000 psi
Caliper range: 75mm to 700mm maximum

Part Numbers

1017950 4-Arm Caliper module

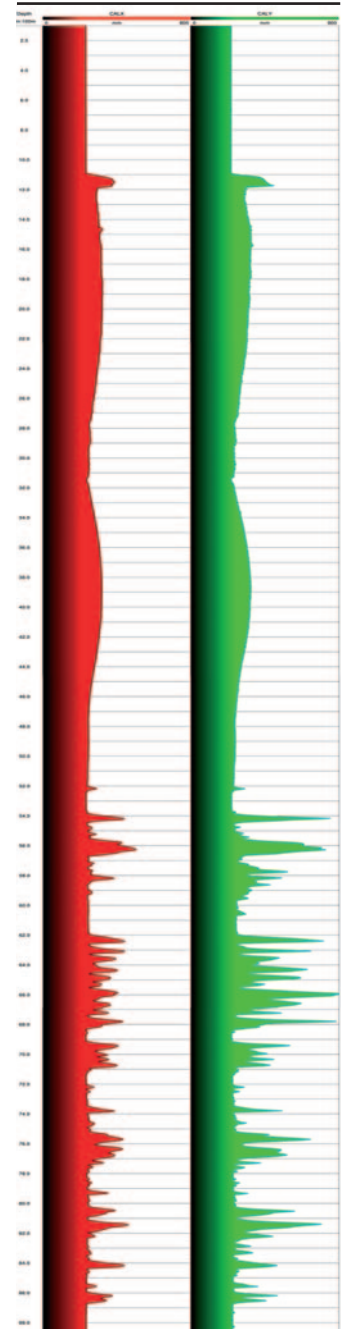

Example of logging data

Ultrasonic Noise Detector (GND)

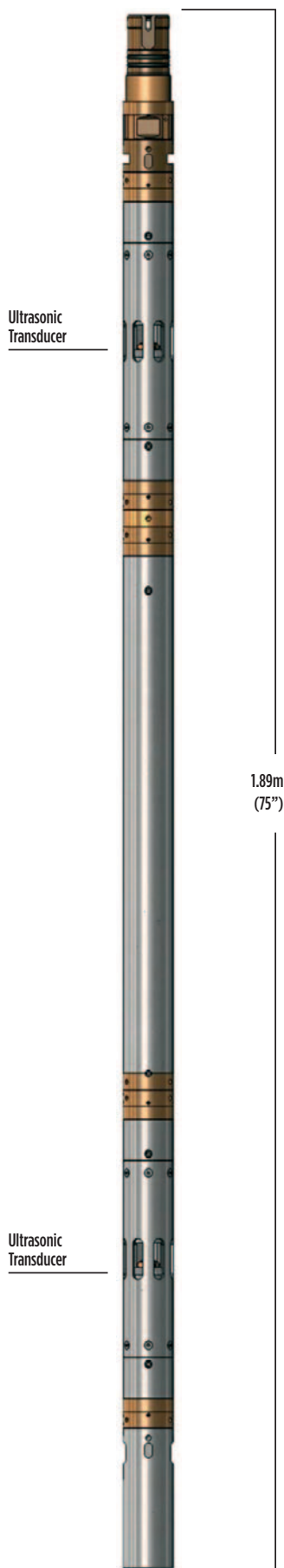

Ultrasonic Noise Detector Module

The Ultrasonic Noise Detector module detects points of entry of high-pressure gas into an open borehole by listening for an ultrasonic signature.

Principle of Measurement:

Sound energy caused by gas entering the borehole is focused by a conical acoustic mirror within the probe onto a microphone. The microphone is tuned to measure the acoustic energy in a frequency band centred at 40kHz, characteristic of entry of high pressure gas through a narrow orifice.

SPECIFICATION:

Features

- Dual detectors in a differential configuration to reduce background noise
- High-sensitivity microphones with acoustic focusing
- Fully digital telemetry combines with density, neutron and other logging probes
- Easy field access for replacement of microphones

Measurements

- Mean acoustic energy within a fixed passband centred at 40kHz

Applications

- Gas detection

Operating Conditions

- Borehole type: Dry open hole only

Specifications

- Diameter: 63mm (2.5")
- Length: 1.89m (75")
- Weight: 26.5kg (58.4lb)
- Max. temperature: 125°C
- Max. pressure: 1MPa

Part Numbers

- 1003952 Ultrasonic Noise Detector module

GeoKey® Surface Acquisition System

The GeoKey® Surface Acquisition System is PC-based, running the industry-standard Warrior™ log-acquisition software. The system is configurable and consists of separate 19" rackmounted modules.

At the heart of the system, the Robertson Geo tool interface provides digital bidirectional communications to the tool stack using a high-speed proprietary QAM protocol. The interface is directly compatible with all Robertson Geo oilfield probes without the need for individual specialised tool modules.

GeoKey® Surface Acquisition System

GeoKey® Surface Acquisition System Interface 3U module includes high-speed tool communications, depth and tension.

SPECIFICATION:

Specifications

Power Module 1U panel supplies 0 – 300VDC probe power

System Computer 2U panel-mounted ruggedised Win7/Win10 P

Break-out Panel Optional 1U panel for convenient access to logging lines, depth-encoder outputs and the tension device

Optional Thermal Plotter 2U printer for real-time hardcopy logs

Part Numbers

1016425 GeoKey® Surface Acquisition System data logger

1016325 Cable breakout panel with tension/depth interface

1014946 Rack mounted 8.5" thermal wellog printer

1004010 Warrior™ 8 acquisition software (Robertson Geo version)

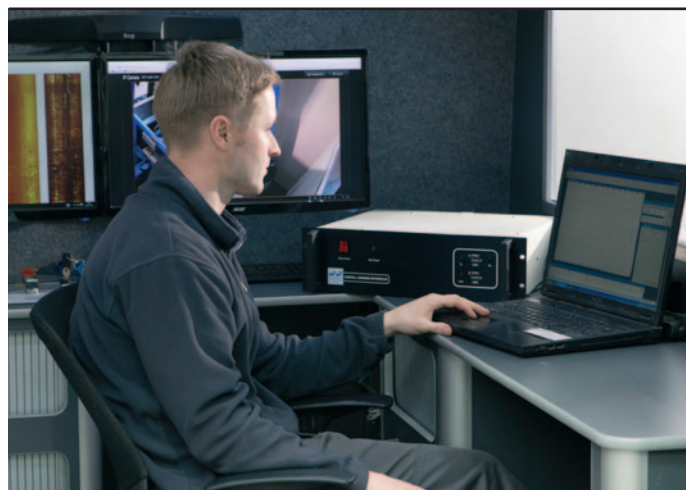

Warrior™ is a trademark of Scientific Data Systems Inc.

Our complete range of brochures:

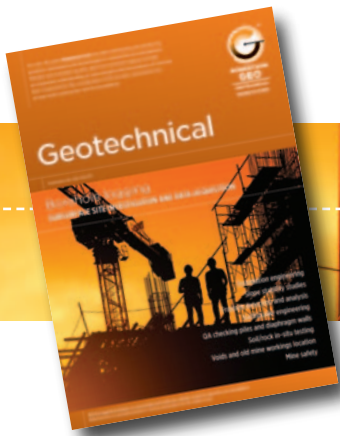

Geotechnical
SUBSURFACE SITE INVESTIGATION AND
DATA ACQUISITION



Mining & Minerals
SUBSURFACE RESOURCE EXPLORATION
AND MINE SAFETY PLANNING

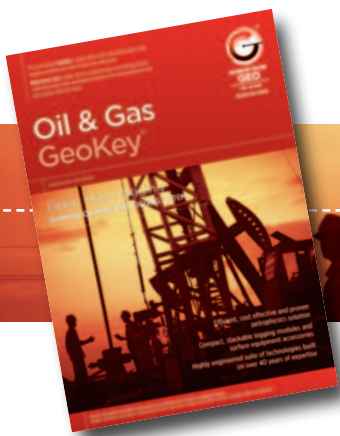

Oil & Gas GeoKey®
SLIMHOLE OR THRU-PIPE OPEN HOLE
LOGGING SYSTEM



Renewables
SUBSURFACE DATA ACQUISITION
AND CHARACTERISATION



Water & Environmental
SUBSURFACE CHARACTERISATION AND
DATA ACQUISITION



Services
COMPREHENSIVE GROUND INVESTIGATION SERVICES,
DATA MANAGEMENT AND RENTAL SOLUTIONS



**ROBERTSON
GEO**

Unlocking Your GeoData

Robertson Geologging Ltd.

Deganwy, Conwy, LL31 9PX,
United Kingdom

T: +44 (0) 1492 582 323

E: info@robertson-geo.com

Robertson Geologging (USA) Inc.

1809 N. Helm Ave., Suite 4,
Fresno, CA 93727, USA

T: +1 (559) 456 1711

E: sstroud@robertson-geo.com

Robertson Geologging (Asia) Inc.

Flat 21A, Village Tower, 7 Village Road,
Happy Valley, Hong Kong

T: +852 650 33486

E: steveparry@robertson-geo.com

www.robertson-geo.com



ISO 9001
Certified
Quality Management System

www.tuv-sud.com/ms-cert

Copyright Robertson Geologging Ltd
© all rights reserved.